

Two-Ring Door Instructions

Installation Manual

PNEG-301

Date: 01-22-08

GSI GROUP



PNEG-301

Contents

Chapter 1 Installation	4
Two-Ring Door Installation	4
Two-Ring Door Assembly	6
Inner Door Auger Hood (Optional)	8
Bin Step (Optional)	8
Door Hinge Installation Instructions	9

1. Installation

Two-Ring Door Installation

Before beginning the installation, be sure the correct door has been received.

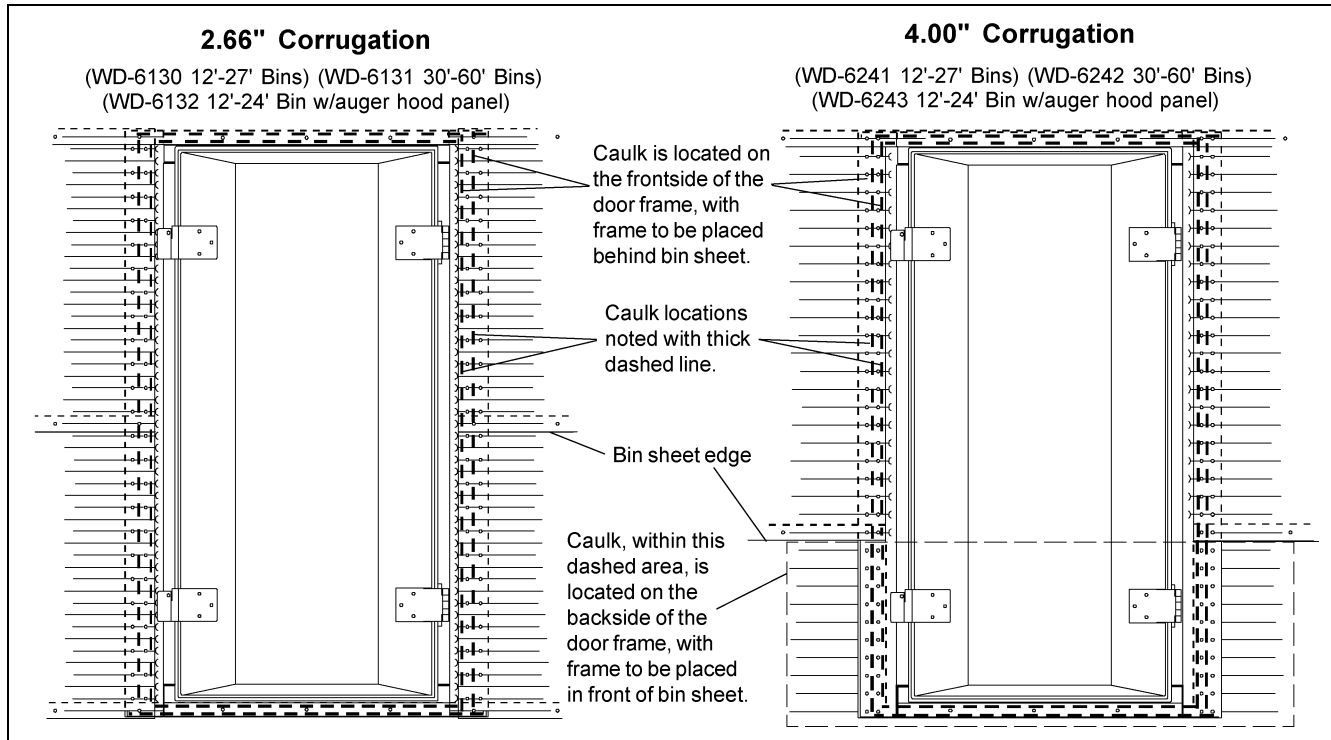

Figure 1A

1. Remove inner door panels and outer door cover. Apply two rows of rope caulk around all four (4) door flanges: On vertical flanges, one row of caulk should be applied between the two vertical rows of bolts and the other row of caulk should be applied between the door frame and the first row of vertical bolts. On the horizontal flanges, a row of caulk should be applied on each side of the row of bolts.

NOTE: For the 2.66" corrugation, all caulk is applied to the outside of the door flanges and the door flanges are applied to the inside of the sidewall.

NOTE: For 4.00" corrugation: the top of the door frame goes to the inside of the sidewall and the bottom of the door frame goes to the outside of the sidewall. Therefore, depending upon location and overlap, caulk will be applied on either the inside or the outside of the door flanges. See Figure 1A for illustration.

With inner door panels and outer door cover removed, set door frame into opening. Insert several bolts at four (4) corners of door frame and sidewall, do not tighten until completing [Step #2](#).

2. Reinstall inner door panels at original locations. Close latch bars to lock panels in place. Be sure that panels are fully seated over all bearing pins. Install inner panel hinge assemblies per instructions in manual PNEG-301 with hinges. **NOTE:** Do not distort door frame with use of alignment or drift punches - if necessary, drill or ream holes to insert bolts in door frame. Now tighten frame bolts starting at center and working toward top and bottom on each side. (On 2.66" corrugation bins, be sure bottom ring of sidewall is installed before tightening these bolts.)
3. To make panels easier to operate, loads on pins should be uniform. To do this, loosen all bearing pin bolts with inner panels latched. Then, retighten all bearing pin bolts.

4. If some latch bars are loose or require excessive force to lock, loosen hex socket capscrews and adjust in or out until latch bars operate smoothly. Check that the panels are fully seated over all bearing pins.
5. Re-install outer cover. Adjust outer door hinges and latches as required.
6. Assemble door hold back as shown [on Page 6](#). Open door cover until it approaches the bin wall. Hook retaining bracket over lower latch mount and position the door hold back against bin wall in a valley. Drill a 3/8" hole through the bin wall and bolt the door hold back to the bin.

Two-Ring Door Assembly

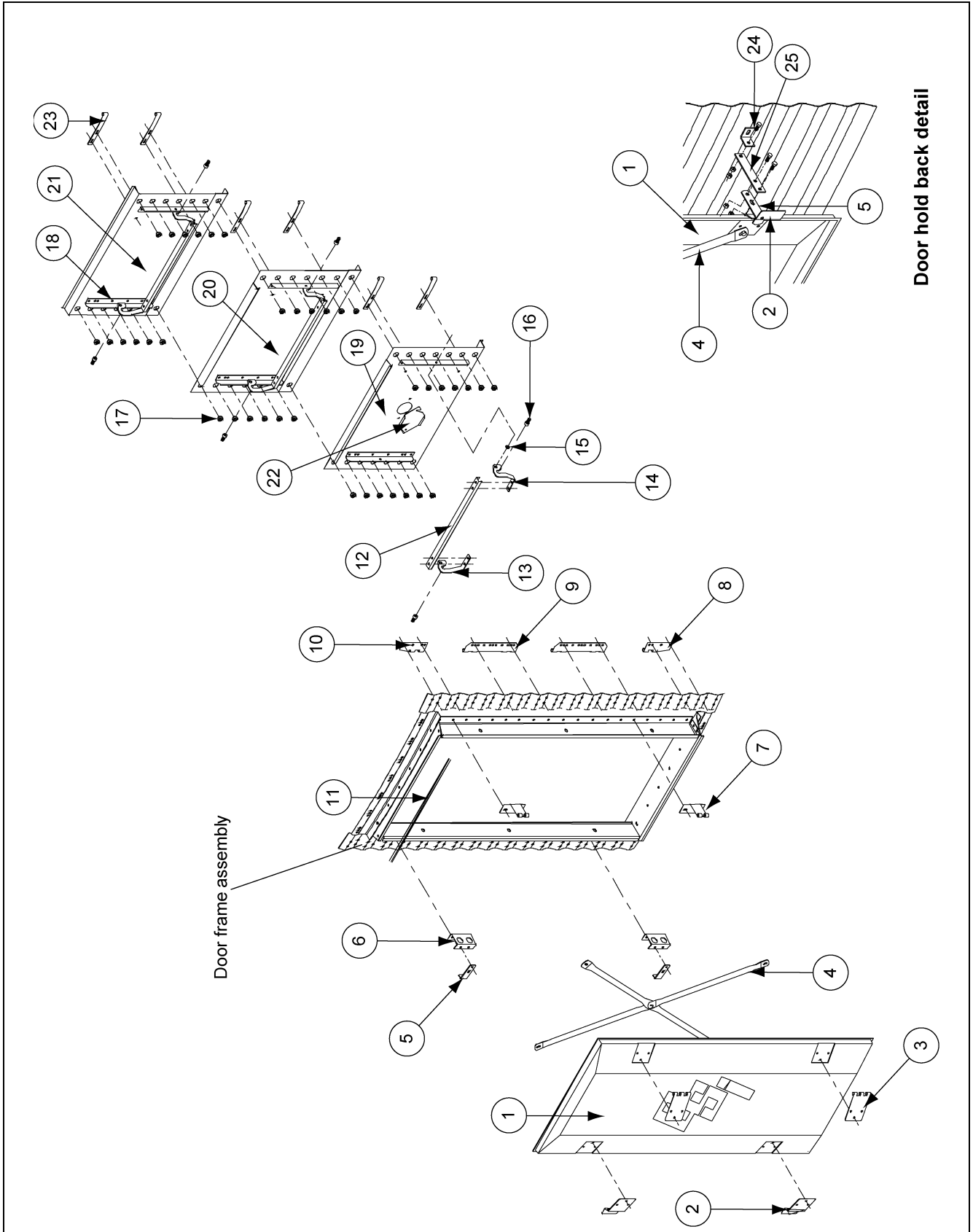

Figure 1B

Parts List for Two-Ring Doors

KEY	PART #	DESCRIPTION	QTY
	12'-27' and 30'-60' BIN DIAMETER		12'-27' and 30'-60' BIN DIAMETER
	2.66" and 4.00" CORR.		
1	WD-039	OUTER DOOR COVER	1
2	WD-2854	OUTER COVER LATCH BRACKET	2
3	WD-225	OUTER COVER HINGE BRACKET	2
4	WD-035	DOOR COVER BRACE SECTION	4
5	WD-033	DOOR RETAINER	3
6	WD-6124	OUTER COVER LATCH MOUNT BASE	2
7	WD-6066	OUTER COVER HINGE BASE	2
8	WD-6055	BOTTOM INNER DOOR HINGE	1
9	WD-6056	MIDDLE INNER DOOR HINGE	2
10	WD-6054	TOP INNER DOOR HINGE	1
11	S-4380	RUBBER TRIM SEAL STRIP	2-1/4 FT.
12	WD-6039	LATCH BAR	3
13	WD-6037	INNER PANEL LATCH - RIGHT HAND	3
14	WD-6038	INNER PANEL LATCH - LEFT HAND	3
15	WD-6040	LATCH BUSHING	6
16	S-8648	1/2" X 1-1/2" HEX SOCKET CAPSCREW	6
17	WD-6079	LONG BEARING PIN	38
18	WD-6125	INNER PANEL REINFORCING ANGLE	6
19	WD-6128	BOTTOM INNER DOOR PANEL	1
20	WD-6127	MIDDLE INNER DOOR PANEL	1
21	WD-6126	TOP INNER DOOR PANEL	1
22	WD-6028	BOTTOM INNER DOOR PORT HOLE COVER	1
23	WD-6053	INNER DOOR HINGE STRAP	6
24	WD-1302	DOOR HOLD BACK BRACKET	1
25	WD-6110	DOOR HOLD BACK EXTENSION	1

Inner Door Auger Hood (Optional) 12' (3.66 m) - 24' (7.32 m) Diameters Only

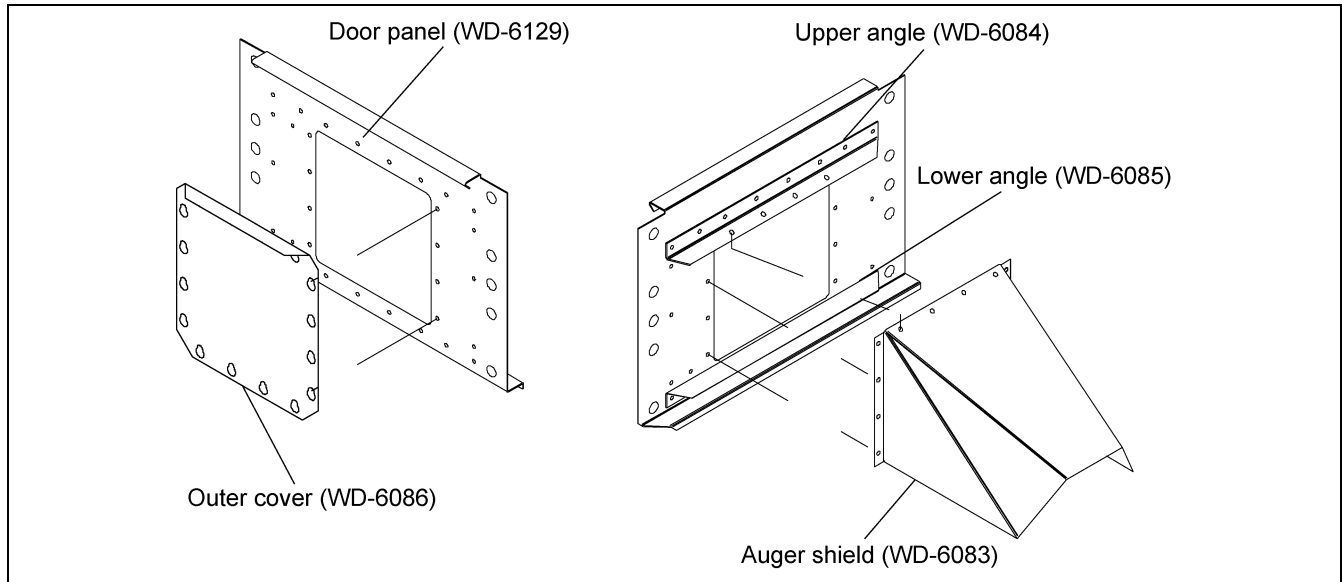

Figure 1C

Remove bolts, lock washers and nuts along each side of large square opening. Position auger shield as shown in [Figure 1C](#) and bolt to underside of top angle with bolt heads under shield. Replace bolts, lock washers and nuts along sides of opening.



Unloading grain through door opening may cause grain bin failure if not done properly. Unloading directly through the door opening should be limited to grain bins no larger than 24' (7.32 m) diameter and grain depths no greater than 18' (5.49 m).

Unloading from the door opening should be done only with use of an auger hood with the auger inserted through the opening to the center of the grain bin.

Bin Step (Optional)

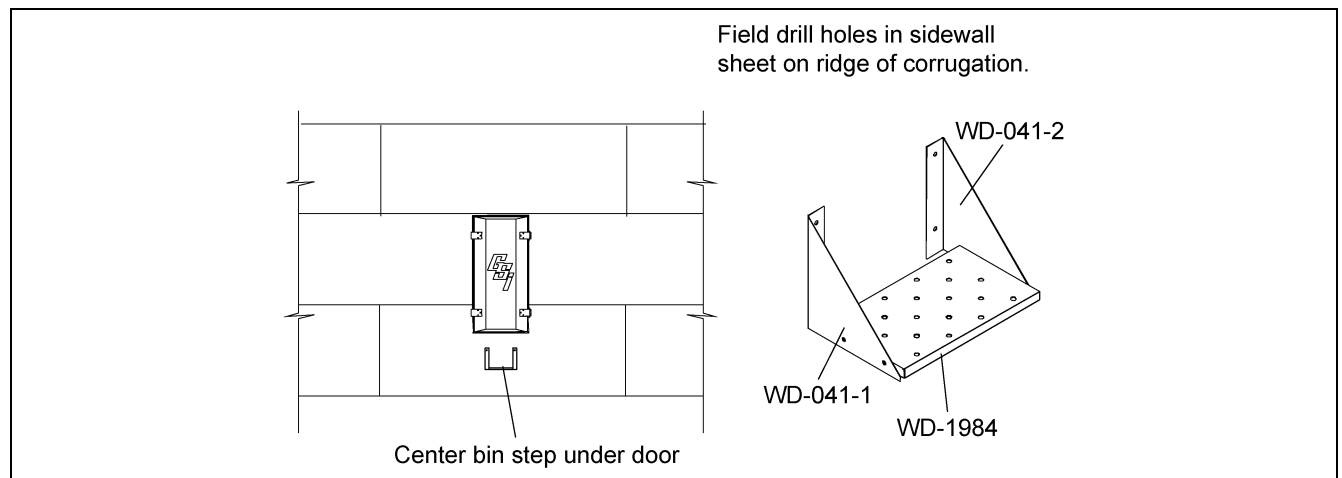

Figure 1D

Door Hinge Installation Instructions

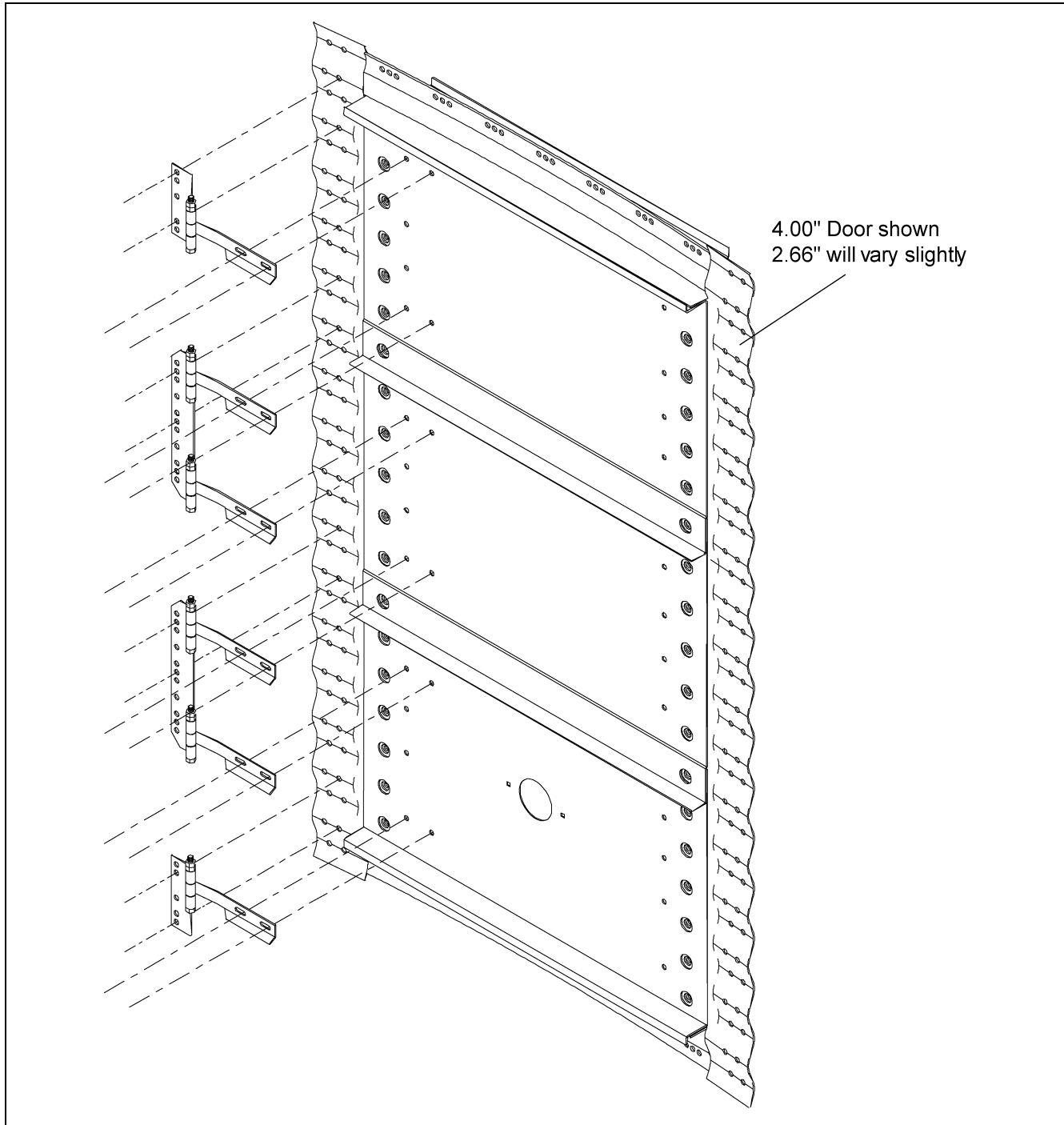

Figure 1E

Viewed from the Inside of the Bin

During door frame and inner panel installation, install hinges in position as shown. (**NOTE:** *Head of bolt with neoprene washer to be on the outside of the bin.*) Attach hinge frame half using only existing frame to sidewall bolts. All frame to sidewall bolts must be installed.

This equipment shall be installed in accordance with the current installation codes and applicable regulations which should be carefully followed in all cases. Authorities having jurisdiction should be consulted before installations are made.

G S I G R O U P



GSI Group
1004 E. Illinois St.
Assumption, IL 62510-0020
Phone: 1-217-226-4421
Fax: 1-217-226-4420
www.gsiag.com